

Investigating Discrepancies In Reliability Coefficient of Survey of Students' Attitudes Towards Statistics (Sats 36) For A Pakistani Sample	العنوان:
المجلة التربوية الدولية المتخصصة	المصدر:
دار سمات للدراسات والأبحاث	الناشر:
Ashrafi, Ghulam Muhammad	المؤلف الرئيسي:
Tariq, Muhammad Ilyas(Co-Auth)	مؤلفين آخرين:
مج 4, 7ع	المجلد/العدد:
نعم	محكمة:
2015	التاريخ الميلادي:
تموز	الشهر:
201 - 225	الصفحات:
843784	رقم MD:
بحوث ومقالات	نوع المحتوى:
English	اللغة:
EduSearch	قواعد المعلومات:
الطلاب الإحصاء (SATS 36) الإحصائي الأسلوب ، ،	مواضيع:
http://search.mandumah.com/Record/843784	رابط:

**INVESTIGATING DISCREPANCIES IN
RELIABILITY COEFFICIENT OF SURVEY OF
STUDENTS' ATTITUDES TOWARDS
STATISTICS (SATS 36) FOR A PAKISTANI
SAMPLE**

GHULAM MUHAMMAD ASHRAFI*

MUHAMMAD ILYAS TARIQ**

* Lecturer _ Department of Education _ University of Sargodha

** Founding Director _ University of Sargodha

INVESTIGATING DISCREPANCIES IN RELIABILITY COEFFICIENT OF SURVEY OF STUDENTS' ATTITUDES TOWARDS STATISTICS (SATS 36) FOR A PAKISTANI SAMPLE

ABSTRACT— This study aims to investigate discrepancies in reliability coefficient of survey of students' attitude towards statistics in Pakistani sample. The study was descriptive in nature and survey design was used to collect data. The sample consisted of 201 undergraduate, graduate, and postgraduate of computer science, mathematics, and education students enrolled at University of Sargodha, Sub Campus Mianwali in statistics course. The instrument SATS 36 proposed by Schau (2003) was adopted. It contains six components i.e. affect, cognitive competence, value, difficulty, interest, and effort pertaining to the student's attitude towards statistics. The Cronbach's alpha (internal consistency) value of the SATS 36 was found to be 0.862. A difference was noted between Cronbach's Alpha values in this study and the study conducted by Schau (2003) not only the composite but also in the sub components. Statistical techniques to measure the reliability estimates were applied to analyze the item statistics, Inter-item correlation matrix, correlation matrix, factor analysis, item-total statistics, and scale statistics of attitudes. Furthermore, descriptive analytical approach was applied to analyze attitude of students across gender, age, discipline, admission in program, and residence. It was concluded that in Pakistani sample, difference in Cronbach's Alpha and other statistical measures were due to context, scale, sample and sample size, poor research culture, learning environment.

KEYWORDS: Cronbach's alpha, reliability, item statistics, Inter-item correlation matrix, item-total statistics, and scale statistics.

I. INTRODUCTION

Literature shows that graduate students' beliefs are unconstructive regarding statistics course as they feel stress and anxiety towards the attainment of their degree. These negative attitudes create obstacle in the minds of learners hence they gave negative views towards statistics [1]. It is fact that statistics course is being offered in academic institutions of Pakistan since a long time but little concern has been given toward factors affecting students' attitude towards statistics. According to the research findings of Gal and Ginsburg [2], it is necessary to give attention statistics students' motivation, feelings, beliefs, expectations, and attitudes to improve the quality of teaching and learning process as students feel trouble with statistics course.

An instrument for gauging students' attitude towards statistics was developed by Schau and her colleagues

containing thirty-six items on a 7-point Likert's response scale in early 90's. It knows as The Survey of Attitudes Toward Statistics (SATS©) containing six components of attitudes i.e. Affect, Cognitive Competence, Value, Difficulty, Interest and effort. It can be administered more often but usually twice as Pretest and Posttest. Students responds as 1 = "Strongly Disagree"; 4 = "Neither Disagree nor Agree" (neutral); 7 = "Strongly Agree". Higher item responses mean more positive attitudes, and responses to items that are negatively worded are reversed before scoring [3]. The SATS© six Attitude Components include the first component Affect comprised of 6 items about students' feelings concerning statistics; the second component is Cognitive Competence comprised of 6 items about their skills and intellectual knowledge towards statistics; the third subcomponent is Value comprised of 9 items the worth, usefulness, and relevance of their professional and personal life; the fourth subcomponent is Difficulty comprised of 7 items about the difficulty of statistics as a subject; the fifth subcomponent is Interest comprised of 4 items about students' level of interest in statistics; and the sixth and last subcomponent is Effort comprised of 4 items about amount of work statistics students expend. Moreover, the survey also includes items that assess student characteristics and previous achievement [4].

Instructors who teach statistics have to encounter problems when teaching statistics courses at graduate and undergraduate level [5]. Students take statistics courses with stress and fear as well as give negative views about their ability and skills of numerical problems [6,2]. It is the need of time that statistics has become the major need of present era and attitude towards statistics are defined as multidimensional concept pertaining to favorable and unfavorable responses (Chiesi & Primi, [7]; Gal, Ginsburg, & Schau, [8]; Schau, Stevens, Dauphinee, & Del Vecchio, [3]). Statistics course has become compulsory requirement in undergraduate, graduate, and postgraduate programs for the fulfillment of requirement of different degrees in various disciplines but still students are reluctant as they feel anxiety taking this course [1]. Statistics students feel that they are incompetent to acquire the required

conceptual understanding about the course especially in the behavioral and social sciences [9]. Keeping in view the statistics course as need of the hour, it is widely recognized that it has gained importance in the introductory statistics course (Gal et al., [8]; Leong, [10]).

Several factors affect the learning of a student in the classroom even when teachers are expecting that they are presenting in authentic way, therefore, positive attitude towards statistics leads towards success (Barton, [11]; Furinghetti and Pekkonen, [12]). Attitude assessment is important to know about the feelings, opinions, attitude, and expectations of students to evaluate the effectiveness of educational programs. In addition to this, it is the conventional practice of research that this sort of investigation has positive impact on statistics students' attitudes (Carnell, [13]; Keeler & Steinhorst, [14]; Leong, [10]; Mills, [15]; Shultz & Koshino, [16]; Suanpang, Petocz, & Kalceff, [17]). Moreover, students' difficulties regarding statistics course can be identified helping to improve their performance [18,19]. Several researchers had already been initiated the evaluation of attitudes towards statistics to provide a proper assessment tool (Roberts & Bilderback, [20]; Schau et al., [3]; Wise, [21]). This situation led academicians to explore opinions, attitude, beliefs, and expectations of students towards statistics course (Gal & Ginsburg, [2]; Garfield, Hogg, Schau, & Whittinghill, [22]; Schau, Dauphinee, & Del Vecchio, [3]).

Roberts and Bilderbeck [20] developed the first assessment scale Statistics Attitude Survey for assessing the needs of students and instructors at undergraduate, graduate and postgraduate level. In the 80s and 90s, many other tools regarding students' attitude towards statistics (Roberts & Bilderback, [20]; Wise, [21]; Zeidner, [23]) having some limitations which led Schau, Stevens, Dauphinee, and Del Vecchio [3] to develop the Survey of Attitudes toward Statistics (SATS). Attitude towards statistics are basically students' attitude towards the statistics course (Cashin & Elmore, [6]; Wise, [21]). Hatcher [24] explained that constructing an instrument is not enough. It is essential to use that instrument which is reliable and valid for evaluating students' attitude towards statistics. It should also identify the possible flaws and pitfalls for the acceptability of data so that it can measure the construct in a standardized way. Although some studies explored the attitudes of students regarding statistics but still a limited insight about the selection and combination of items has been overviewed (Cashin & Elmore, [18]; Chiesi & Primi, [7]; Dauphinee, Schau, & Stevens, [25]; Hilton, Schau, & Olsen, [26]; Schau et al., [3]; Tempelaar, van der Loeff, & Gijsselaers, [27]). Therefore, the importance of statistics course shows that further studies should have been conducted to investigate and clarify the impact of students' attitude toward statistics. Researchers have reported that statistics

students' attitudes are significantly and positively correlated with the academic performance in statistics course in higher education setting (Araki & Schultz, [28]; Schulz & Koshino, [16]). They are of the view that students' grades would be affected if they have negative views in statistics course. Few researchers conducted studies on the gender differences of students' attitudes towards statistics and found mixed attitudes (Araki & Schultz, [28]; Cashin & Elmore, [18]; Roberts & Saxe, [19]; Waters et al., [1]).

As statistics education is important in many walks of life for making predictions and decision but in spite of this less attention is given in this scenario (Jordan & Haines, [29]; Schield, [30]). Phillips (1980) refers that the students' attitude towards statistics can cause obstacle. Furthermore, by Gal & Ginsburg [2] and Ginsburg & Schau [31] argued that students' attitude towards statistics are an essential component to carry out academic and professional activities. In addition to this Wise [21] and the scale of Auzmendi [32] collected useful characteristics of students' attitude towards statistics and difficulties faced by students in statistics course. Mondejar, Vargas and Bayot, [33] also developed a test based on the methodological principles of Wise [21] attitude toward statistic (ATS) comprised of 29 items grouped in two scales, one that measures the affective relationship with learning and cognitive measures the perception of the student with the use of statistics and scale attitude toward statistics (SATS) of Auzmendi [32]. Mondéjar et al [33] describe the psychometric properties of students' attitudes towards statistics to measuring the affective factors of students. They refer to the validation that was based on a very small sample. Further studies showed that Mondejar et al [33] or Woehlke [34] corroborated this structure. Another study conducted by Gil [35] depicted five factors in this regard: one of the emotional factor and the remaining four factors related cognitive component but the studies of Elmore and Lewis [36] and Schau et al [3] have derivative works.

In 1980, Roberts and Bilderback published the Statistics Attitude Survey (SAS). The main purpose of this instrument was whether it was an effective measure in the prediction of performance in statistics. Wise [21] argued that the SAS was an invalid measure of statistics attitudes and published the Attitude Toward Statistics (ATS) scale. Roberts, Bilderback, and Saxe [19] argued that students' attitudes toward statistics are significant in student success. For this purpose, several past studies shows statistics anxiety found strong correlations of statistics students' attitudes with their academic performance. Another reliable measure of the Survey of Attitudes Toward Statistics (SATS) developed by Schau et al. [3], argues that attitude toward statistics was comprised of four components: affect, cognitive competence, value, and difficulty, however, few researchers disagree the

aforementioned factors comprising students' attitude towards statistics. Different measures are available in this regard i.e. Statistics Attitude Survey [20], Statistics Attitude Scale [37], Survey of Attitudes Toward Statistics [3], and the Attitude Toward Statistics scale [21]. In the literature of statistical studies conducted over the past few decades, this relationship has been discussed, but the tool developed by Schau [38] known as Survey of Attitudes Towards Statistics (SATS-36, Copyright ©) can however measure the best possible construct of six attitudinal components i.e. Affect, Cognitive Competence, Value, Difficulty, Interest and Effort due to its well-known psychometric properties and reliability, validity practices in statistics education research [26] Tempelaar, Schim van der Loeff, & Gijsselaers, [27]; Vanhoof, Kuppens, Sotos, Verschaffel, & Onghena, [39]). It plays crucial role for statistics teaching and learning as well as value and belief of students' achievement in statistics (Mullis, Martin, Gonzalez, Conner, Chrostowski, Gregory, Garden and Smith, [40], Farooq & Shah, [41]). Blanco [42] described some inventories test that measure students' attitude towards statistics with a critical review over the instrument, but it is obvious from past studies that the first operative definition about attitude towards statistics was given by Roberts and Bildderbach [20] in the Statistics Attitudes Survey (SAS) and it is considered the first measure about construct of attitude towards statistics [43].

Berkowitz, Wolkowitz, Fitch and Kopriya [44] explained that reliability is the degree to which test scores of test takers are consistent over repeated procedures of a measurement process and therefore it may be inferred that they are repeatable and dependable for test takers. According to Crocker and Algina [45], reliability is a property of the scores for a particular group of test takers. It is also the indicator of the absence of error to show that how error free and consistent measurements are [46]. It was further opined by Rudner and Schafer [47] that the best way to view reliability is the extent to which test measurements are the result of properties of people being measured and the test scores are reliable only in that case if they are true representative of test takers. If test scores will vary, the tests are no more dependable and repeatable. Meadows and Billington [48] argued that score reliability

estimates are affected by group heterogeneity with respect to the trait being measured. They depicted that a measurement reliability of a heterogenous group is higher than that of a more homogenous group with regard to the trait being measured while only true score variance varies with group heterogeneity. Raykov and Marcoulides [49] explained psychometric theory to explain reliability and validity of an instrument. Fan and Yin [50] argued that group performance level affects measurement reliability. They examined that the difference in measurement reliability is higher between the high and low performing groups if there is the larger performance difference while measurement reliability estimates are consistent with the empirically observed measurement reliability estimates. Wiliam [51] was concerned about the particular choice of items included in the test as most tests are a selection of items to test particular skills, therefore, he indicated three major sources of assessment errors influencing the overall reliability of the assessment i.e. factors in the test itself, factors in the candidates taking the test and scoring factors such as test raters. The second source of error may be inconsistent that introduce error in the testing process as the test taker may have to face fatigue, changes in test taker's concentration, health, attitudes, and so many factors that can contribute to affect responses hence resulting in omitting test sections, misread test items, misinterpret test instructions, making careless errors or forgetting test items to respond on them. Harper [52] argued that confusing examiner reliability and examination reliability may be cause by scoring factors which shows that the reliability of the total testing situation is not only affected by scoring factors but also a combination of test reliability, the candidates and examiner reliability.

Reliability is used to measure some attribute or behavior and consistency of measurement over time. It is estimated with a measure of association called as reliability coefficient that is the correlation between two or more variables which measure the same thing e.g. tests, item, or raters [53]. Methods to estimate test reliability are: test-retest reliability, alternative forms, split-halves, inter-rater reliability, and internal consistency which are depicted in Figure 1 showing three main concerns stability over time, equivalence, and internal consistency.

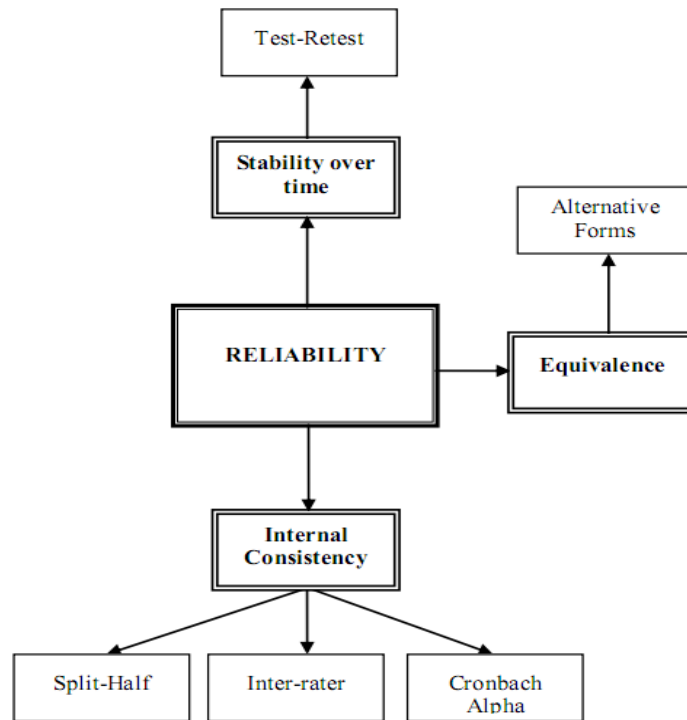

Figure 1
Reliability of Measurement Tests

Drost [54] explained that Test-retest reliability is the stability of a test from one measurement session to another. In addition to this, the second form of estimating reliability is alternative technique which is similar to the test retest method in which different measures of a behavior are collected at different times [55]. Whereas, the third form of test reliability is split-half approach which assumes that half of the items are combined to form one new measure and the other half is combined to form the second measure resulting in two new measures testing the same behavior [55,56]. The fourth form of estimating reliability is Inter-rater reliability used to measure the combined internal consistency of judgments or the reliability of their judgments is assessed [53]. The last form of measuring reliability is internal consistency which measures consistency within the instrument. In this form, estimates are based on inter-correlations among all the single items within a test to measure a particular characteristic or behavior within the test [54]. In behavioral sciences, the most popular method of testing for analyzing internal consistency is coefficient alpha introduced by Cronbach (1951). It is, therefore, often referred to as Cronbach's alpha because of its originator. It is observed that coefficients of internal consistency increases to a certain point as the number of items goes up. The individual item would have small correlation with true scores. It would be expected that test is too short or the items have very little in common, if coefficient alpha tends to be very low [57].

The present study was designed to use the Schau's scale of students' attitude towards statistics in a Pakistani sample to provide teachers and instructors an insight about discrepancies between the reliability estimates of SATS 36

of present study and the study conducted by Schau [38] so that we can get more reliable and valid results. The Schau's scale attitude toward statistics was used to collect the necessary data to examine its psychometric properties. The attitudes of undergraduate, graduate, and postgraduate students from a Pakistani sample, enrolled in public sector universities, were taken to measure students' attitudes towards statistics and to find discrepancies of reliability estimates between the present study and the study conducted by Schau [38]. This study would answer the possible questions regarding the level of students' attitude towards statistics and reliability estimates of six factors of SATS 36 i.e. Affect, Cognitive, Competence, Value, Difficulty, and Interest.

As the major purpose of this study was to adapt the Survey of Attitudes towards Statistics (SATS 36) (Schau, [38]) for Pakistani sample and find difference between Cronbach's Alpha values for the present study and study conducted by Schau [38] not only in the composite but also the sub components of SATS 36 with the help of applying different statistical techniques including Inter-item correlation matrix, correlation matrix, item-total statistics, and scale statistics of attitudes to measure the reliability estimates in Pakistani context.

It has been explored that statistics students feel difficulty in choosing this course because of the conflict between expectations and reality [58]. Therefore, it is the need of time that further research should be conducted in various contexts and localize the SATS 36 instrument to find discrepancies in reliability coefficient of statistics attitude of university students in a Pakistani sample.

II. STATEMENT OF THE PROBLEM

A. OBJECTIVES OF THE STUDY

Following were the objectives of the study:

- 1) To identify the demographic characteristics of undergraduate, graduate, and postgraduate students in Pakistani sample of public sector universities using Schau's (2003) instrument of Students' Attitude Towards Statistics with respect to gender, age, discipline, admission in program, and residence.
- 2) To analyze the discrepancies of reliability estimates of undergraduate, graduate, and postgraduate students in Pakistani sample of public sector universities using Schau's (2003) instrument of Students' Attitude towards Statistics in present study and the study conducted by Schau (2003).
- 3) To explore the item-wise statistics of undergraduate, graduate, and postgraduate students in Pakistani sample of public sector universities using Schau's (2003) instrument of Students' Attitude towards Statistics.
- 4) To evaluate the difference between descriptive statistics of undergraduate, graduate, and postgraduate students in Pakistani sample of public sector universities using Schau's (2003) instrument of Students' Attitude towards Statistics in present study and the study conducted by Schau (2003).
- 5) To investigate the factor analysis of undergraduate, graduate, and postgraduate students in Pakistani sample of public sector universities using Schau's (2003) instrument of Students' Attitude towards Statistics.
- 6) To determine the Inter-Item Correlation of undergraduate, graduate, and postgraduate students in Pakistani sample of public sector universities using Schau's (2003) instrument of Students' Attitude towards Statistics.
- 7) To examine the Correlation Matrix of undergraduate, graduate, and postgraduate students in Pakistani sample of public sector universities using Schau's (2003) instrument of Students' Attitude towards Statistics.
- 8) To interpret the Item-Total Statistics of undergraduate, graduate, and postgraduate students in Pakistani sample of public sector universities using Schau's (2003) instrument of Students' Attitude towards Statistics.
- 9) To summarize the Scale Statistics of undergraduate, graduate, and postgraduate students in Pakistani sample of public sector universities using Schau's (2003) instrument of Students' Attitude towards Statistics.

B. RESEARCH QUESTIONS

Following were the research questions of the study:

- 1) How undergraduate, graduate, and postgraduate students are the demographically scattered in Pakistani sample of public sector universities using Schau's (2003) instrument of Students' Attitude Towards Statistics with respect to gender, age, discipline, admission in program, and residence?
- 2) What are the discrepancies of reliability estimates in

Pakistani sample of undergraduate, graduate, and postgraduate students of public sector universities using Schau's (2003) instrument of Students' Attitude towards Statistics in present study and the study conducted by Schau (2003)?

3) What are the item-wise statistics of undergraduate, graduate, and postgraduate students in Pakistani sample of public sector universities using Schau's (2003) instrument of Students' Attitude towards Statistics?

4) What are the differences in descriptive statistics of Pakistani sample for undergraduate, graduate, and postgraduate students in public sector universities using Schau's (2003) instrument of Students' Attitude towards Statistics in present study and the study conducted by Schau (2003)?

5) What is the factor solution for undergraduate, graduate, and postgraduate students of Pakistani sample in public sector universities using Schau's (2003) instrument of Students' Attitude towards Statistics?

6) What is the Inter-Item Correlation among undergraduate, graduate, and postgraduate students of Pakistani sample in public sector universities using Schau's (2003) instrument of Students' Attitude towards Statistics?

7) What is the Correlation Matrix of undergraduate, graduate, and postgraduate students in Pakistani sample of public sector universities using Schau's (2003) instrument of Students' Attitude towards Statistics?

8) What is the Item-Total Statistics of undergraduate, graduate, and postgraduate students in Pakistani sample of public sector universities using Schau's (2003) instrument of Students' Attitude towards Statistics?

9) What is the Scale Statistics of undergraduate, graduate, and postgraduate students in Pakistani sample of public sector universities using Schau's (2003) instrument of Students' Attitude towards Statistics?

III. Method

This study is non-experimental, transversal, and descriptive in nature, because we need to know the attitude toward statistics in university students in Public Sector University. The study was conducted in University of Sargodha Sub-Campus Mianwali and the participants were selected using probability and non-probability sampling technique. Therefore, purposive sampling technique was used to choose departments and cluster sampling technique to choose students for the sample. Two hundred and one students Mianwali Campus were surveyed and the data was taken from three disciplines; Computer Science and Information Technology, Mathematics, and Education. Students of Computer students, Mathematics, and Education were offered a 3 Credit Hour course as per outline of Probability and Statistics provided by University of Sargodha. The statistics students in three disciplines were taught by two instructors (all male) in the 2nd semester of spring, 2014. The total number of students

enrolled in Mianwali campus was 1470 at the time of data collection. All the sample students enrolled in these programs were contacted for data collection. Two hundred and one students returned the questionnaire. The response rate was 100%. The survey was administered with the prior permission of its developer via E-mail. The high score of SATS 36 represented the higher and more positive attitudes of students towards statistics. It also includes both negative and positive items. The SATS-36© contains 36 items and the subcomponents were: Affect, Cognitive Competence, Value, Difficulty, Interest, and Effort. The items use a 7-point Likert-type response scale to assess the aforementioned six components of students' attitudes toward statistics. Moreover, the survey contains questions about relevant demographic information about gender, age, discipline, admission in program and residential status. A pilot study of 50 economics and business administration students of the University of Sargodha Sub-Campus Mianwali was conducted during April – May 2014 at Mianwali Campus, Pakistan.

The researchers adopted the SATS-36© scale to measure computer science, mathematics, and education students' attitudes toward statistics in a Pakistani. It consists of 36 items which were on seven-point Likert-type from strongly disagree to strongly agree and is divided into six subscales i.e. Affect (feelings concerning

statistics), Cognitive Competence (attitudes toward intellect and skills applied to statistics), Value (attitudes toward the usefulness and relevance of statistics), Difficulty (attitudes toward the difficulty of the subject matter), Interest (attitude to take attention in the subject) and Effort. The instrument used was a survey of attitudes toward statistics or SATS to measure statistics anxiety (Schau et al., [3]; Schau, [38]). The first version of SATS containing 28 items was developed by Schau et al., [3] and updated by adding two subscales in the original version containing 36 items [38]. The first subcomponent (six items) was about the positive and negative feelings concerning statistics students. The second subcomponent Cognitive Competence (six items) was about attitudes related to skills and intellectual knowledge of statistics student. The third subcomponent Value (nine items) was about the worth, usefulness, and relevance their professional and personal life. The fourth subcomponent Difficulty (seven items) was about the difficulty of statistics course. The fifth subcomponent Interest (four items) was about students' interest in statistics course. The sixth and the last subcomponent Effort (four items) was about the amount of effort students spend in statistics course (Schau et al., [3], p.870, Schau, [38]). Scale factors attitude towards statistics describes the indicators, definitions and codes/items in Table 1 below.

Table 1
Scale factors attitude towards statistics

Indicators	Sample items	Items	Total
Affect	I will like statistics.	3, 4, 15, 18, 19, 28	6
Cognitive Competence	I will have trouble understanding statistics because of how I think.	5, 11, 26, 31, 32, 35	6
Value	Statistics is worthless.	7, 9, 10, 13, 16, 17, 21, 25, 33	9
Difficulty	Statistics formulas are easy to understand.	6, 8, 22, 24, 30, 34, 36	7
Interest	I am interested in being able to communicate statistical information to others.	12, 20, 23, 29	4
Effort	I plan to complete all of my statistics assignments.	1, 2, 14, 27	4

The six subscales are formed by 6, 6, 9, 7, 4, and 4 items, respectively. The affect factor indicators are: Item 3, 4, 15, 18, 19, 28; cognitive competence factor indicators are: Item 5, 11, 26, 31, 32, 35; the value factor are: items 7, 9, 10, 13, 16, 17, 21, 25, 33; the difficulty factor indicators are: items 6, 8, 22, 24, 30, 34, 36; the interest factor indicators are; items 12, 20, 23, 29; and the effort factor indicators are; 1, 2, 14, 27. The items are assessed

by a Likert scale 1 to 7 with 1 =“strongly disagree” and 7 =“strongly agree” (4 is neutral) containing 2 and 3 between strongly disagree and neutral zone while 5 and 6 between neutral and strongly agree zone to represent intensity of attitudes. In addition to this, the answers of some negatively worded items should be reversed (1 is replaced by 7, 2 by 6, 3 by 5, 4 by 4, 5 by 3, 6 by 2, 7 by 1) The diagram of factors sequences is shown in Figure 2.

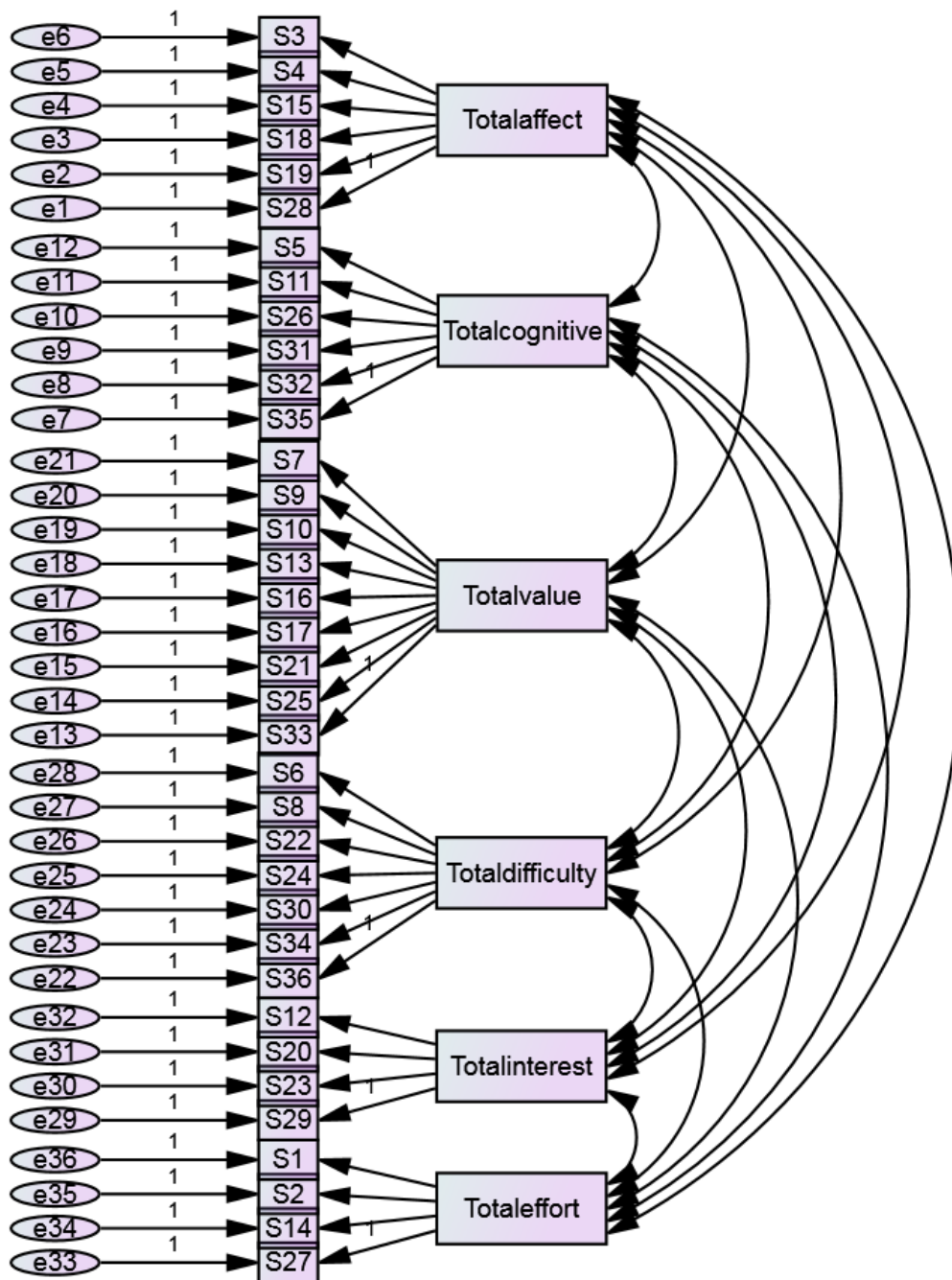

Figure 2

Sequence diagram of students' attitude towards statistics

IV. RESULTS

The most commonly used model is Alpha model of internal consistency. It is based on the average inter-item correlation. We used the Alpha model for calculating the internal consistency in the scale. The researchers can select various statistics that describe the scale and items report by default in SPSS software includes the number of items, the number of cases, and reliability estimates. It

includes Alpha models to calculate coefficient alpha for dichotomous data. It is also equivalent to the Kuder-Richardson 20 (KR20) coefficient. The second mode is Split-half that calculates correlation between form. It includes Guttman split-half reliability, Spearman-Brown reliability for equal and unequal length, and coefficient alpha for each half.

The third mode is Guttman to calculate reliability

coefficients lambda 1 through lambda 6. At the end the Parallel and Strict parallel models may be used to test for goodness of fit of model; estimates of error variance, common variance, and true variance; estimated common inter-item correlation; estimated reliability; and unbiased estimate of reliability [59]. The researchers calculated descriptive statistics for scales or items across cases. All option under descriptive for were checked include Item to produce descriptive statistics for items across cases, Scales to produce statistics for scales, and scale if item deleted to displays summary statistics comparing each item to the scale that is composed of the other items. The statistics also includes inter-item correlations while covariances option under Inter-item; mean, variances, covariances, and correlations under summaries; None, F test, Friedman chi-square, and Cochran chi-square under ANOVA table; Hotelling's T-square; Turkey's test of additivity; and Intraclass correlation coefficient were remained unchecked.

The Demographic Profile

Participants for this study were selected using probability and non-probability sampling techniques. For this purpose, the researcher used purposive sampling technique to chose departments and cluster sampling technique to choose students for the sample. Two hundred and one students Mianwali Campus were surveyed and the data was taken from three disciplines; Computer Science and Information Technology, Mathematics, and Education. Students of Computer students, Mathematics, and Education were offered a 3 Credit Hour course as per outline of Probability and Statistics provided by University of Sargodha. The first objective of the study was to identify the demographic characteristics of undergraduate, graduate, and postgraduate students in Pakistani sample of public sector universities using Schau's (2003) instrument of Students' Attitude towards Statistics with respect to gender, age, discipline, admission in program, and residence. For this purpose, the descriptive statistical technique was applied to know the demographic distribution of sample students as per following table.

Table 2
Demographic Distribution of Students' Sample

Variable	Category	Frequency	Percentage
Gender	Male	128	64
	Female	73	36
	Total	600	100
Age	17 – 21 year	163	81.1
	22—26 year	21	10.4
	27 year or above	17	8.5
Discipline	Computer Science	112	56
	Math	54	27
	Education	35	17
Admission in Program	Regular	145	72
	Self support	56	28
Residence	Rural	59	29
	Urban	142	71

The main study was conducted during the first week of June 2011. The sample consisted of 201 individuals including 112 computer science, 54 Mathematics, and 35 education students of the above mentioned University; 128 students were male and 73 female. The selection criteria were to include students who were studying statistics course in the undergraduate, graduate, and postgraduate programs at the institution to implement the survey. There were 128 (64%) males and 73 (36%) females in the study, 142 (71%) were Urban, 59 (29%) were rural students, and 145 (72%) were Urban, 56 (28%) were rural students. The university participants were selected from three department which including 112 (56%) in computer science, 54 (27%) in Mathematics, and 35 (17%) in education. The age range for the university participants in this study was 17-50 years of age, with a mean of 21. Participants were required to been rolled in a statistics course at the undergraduate, graduate, and postgraduate

level and be a Computer Science, Mathematics, and Education students. The size of the classes ranged from 26 to 55 students. There were significant differences in the gender, age, discipline, admission in program, and residence wise distributions among participants. The data was analyzed by using SPSS version 20.0. The analysis revealed that the response rate for students was 100% (N = 201). The first part of the instrument contained the biographical information regarding their gender, age, discipline, admission in program, residence and general guidelines to fill up the questionnaire along-with ensuring anonymity of the respondents and the standard procedures of research ethics. A notable majority (64%) of males in the sample shows that their aptitude for seeking admission in these programs was relatively more positive than females as well as seven out of ten were in regular program. These three programs were offered in morning and evening times. There were four section in BS

computer science (8 semesters), two section in BS mathematics (8 semesters) and one each section in M.Phil education (4 semesters) and M.Ed (2 semesters) programs. In regard to the admission in programs, more than half (56) students were admitted in BS computer science program. The sample shows that significant proportion (7 out of 10) of the urban area students are admitting in these programs.

The Reliability Analysis

The second objective of the study was to analyze the discrepancies of reliability estimates of undergraduate, graduate, and postgraduate students in Pakistani sample of public sector universities using Schau's (2003) instrument of Students' Attitude Towards Statistics in present study and the study conducted by Schau (2003). The reliability analysis was obtained from the menu of SPSS i.e. analyze, scale and then reliability analysis. We selected all 36 SATS variables into the items list of reliability analysis window. The properties of measurement scales can be studied with the help of reliability analysis. The data used for reliability analysis may be dichotomous, ordinal, or interval, but the data should be coded numerically. The data used in the present study was interval in nature and the observations were independent. It was observed that items were linearly related to the total score and each pair of items have a bivariate normal distribution while error were uncorrelated between items. The reliability analysis calculated SATS 36 scale reliability estimates. The case processing summary shows that there were 201 valid cases in lieu of list wise deletion based on all variables in the procedure while no case was excluded. It also provided

information about the relationships between 36 items of the scale. With the help of this procedure, summary statistics across items, inter-item correlations and covariances, reliability estimates, ANOVA table, intraclass correlation coefficients, Hotelling's T2, and Tukey's test of additivity may be calculated with the help of reliability analysis in SPSS. Five models are available in the reliability estimate test containing Alpha (Cronbach), Split-half, Guttman, Parallel, and Strict parallel.

In order to analyze the psychometric properties of SATS 36, the instrument was administered to 201 graduate students enrolled in an introductory course of statistics in three disciplines at University of Sargodha, Sub Campus Mianwali. Table 3 demonstrates the value of Cronbach's alpha in SPSS for internal consistency reliability analysis. Cronbach's alpha is an estimate of internal consistency associated with the scores that can be derived by a scale or a composite score and the reliability is important because in the absence of reliability it is impossible to have any validity associated with the scores of a scale. If you are combining scores together basically Cronbach's Alpha is helpful to determine the scores that have been aggregated together. To calculate the reliability or Cronbach's alpha specifically SPSS have model options as default having Alpha, Split-half, Guttman, Parallel, and strict parallel models [59]. Descriptive for the item, scale, and scale if item deleted were checked. Inter-item correlations were also calculated. Cronbach's α for attitude toward statistics in the present study and the study conducted by Schau et al. [3,38] is reported in the below-mentioned table.

Table 3
Cronbach's α for attitude toward statistics in our study (n=201) and as reference values reported in Schau et al. [3,38]

Sub components	Items	Cronbach's Alpha for this study	Cronbach's Alpha Based on Standardized Items	Schau, 2003	Average of Cronbach's alpha values
Affect	6	.510	.489	.80 to.89	.84
Cog. Competence	6	.321	.360	.77 to.88	.82
Value	9	.629	.629	.74 to.90	.82
Difficulty	7	.428	.431	.64 to.81	.72
Interest	4	.814	.815	New component	New component
Effort	4	.695	.697	New component	New component
SATS-36	36	.862			

Value of Cronbach's Alpha for present study of SATS 36 was found to be.862. Previous studies showed that SATS has a good internal consistency across samples. It was reported by Schau and et. al [3,38] that the Cronbach's alpha values ranged from 0.80 to 0.89 for Affect, from 0.77 to 0.90 for Cognitive Competence, from 0.74 to 0.91 for Value, and from 0.64 to 0.86 for Difficulty. Apart from the aforementioned components questions about relevant demographic and academic background information which were added to seek views from respondents. The SATS survey was administered to the students of Education, Computer Science and

Mathematics of University of Sargodha, Sub Campus Mianwali. In both programs, the SATS survey was administered at an instructors selected class prior to the final exam. Sample items and internal consistency reliabilities in this study compared to the Schau et al [3,38] study are shown in Table 3 along with sample items and the values of internal consistency reliability (Cronbach's α) from the current study. The comparison between values of Cronbach's alpha for attitude towards statistics in the current study and those reported in the study of Schau was made on the basis of test value.70. For this purpose, values of Cronbach's alpha of 1st four components including

affect, cognitive competence, value, and difficulty were analyzed with the help of One-Sample t-test.

Table 4
Comparison of Cronbach's alpha (Test Value =.70) for SATS 36 in our study (n=201)

Scale	Cronbach's alpha	N	Mean	Std. Deviation	Df	t	Sig. (2-tailed)
Current study	.510, .321, .629, .428	4	.4675	.12790	3	-3.636	.036*
Schau, 2003	.84, .82, .82, .72	4	.8000	.05416	3	3.693	.034*

Table 4 indicates that there is a significant difference between the mean values of Cronbach's alpha for four components including affect, cognitive competence, value, and difficulty and test value (.70) with respect to attitude towards statistics in our study because t-value (-3.636) was found to be significant at .05 level of significance as well as that of reported in Schau (2003) in which t-value (3.693) was also found to be significant at the same level of significance. It means that Cronbach's alpha values reported in the present study were far below the standard value (.70) while for that of Schau's study, these values were quite high. Value of Cronbach's Alpha for the present study was estimated to be .862. Basically it means that 86% variability in a composite score by combining those 36 items submitted for the analysis. This was actually the true score variance or internally consistent reliable variance. SPSS also calculated Cronbach's alpha based on standardized items .863 and usually the difference between the two that this second option calculates

Cronbach's alpha under the pretence that all items have the same variance but in practice usually it is not the case. In most cases both values do not differ so much because people are combining items that roughly have the same standard deviation or variance but sometimes when you are combining dichotomously scored items with ordinal scaled items or interval ratio items you get very big differences between these two [59]. The criterion for determining the acceptable level of reliability has actually not been resolved but there are several recommendations in the most frequently cited recommendations is .70.

Item Statistics

The third objective of the study was to explore the item-wise statistics of undergraduate, graduate, and postgraduate students in Pakistani sample of public sector universities using Schau's (2003) instrument of Students' Attitude Towards Statistics. The description is overviewed with the help of below-mentioned table.

Table 5
Item Statistics for the students' attitude towards statistics (SATS 36) in a Pakistani sample containing six factors

Sub Components	Items	Statements	Mean	SD	N	Rank
Affect	S3	I like statistics.	5.66	1.593	201	6 th
	S4	I feel insecure when I have to do statistics problems.	4.81	1.557	201	33 rd
	S15	I get frustrated going over statistics tests in class.	5.00	1.847	201	26 th
	S18	I am under stress during statistics class.	4.92	2.209	201	29 th
	S19	I enjoy taking statistics courses.	5.01	1.877	201	24 th
Cognitive Competence	S28	I am scared by statistics.	5.03	2.146	201	23 rd
	S5	I have trouble understanding statistics because of how I think.	5.29	1.561	201	15 th
	S11	I have no idea of what's going on in this statistics course.	5.24	1.996	201	16 th
	S26	I make a lot of math errors in statistics.	4.99	1.752	201	27 th
	S31	I can learn statistics.	6.18	1.261	201	1 st
Value	S32	I understand statistics equations.	5.60	1.665	201	7 th
	S35	I find it difficult to understand statistical concepts.	4.89	1.890	201	31 st
	S7	Statistics is worthless.	5.44	1.936	201	10 th
	S9	Statistics should be a required part of my professional training.	5.13	1.832	201	21 st
	S10	Statistical skills will make me more employable.	5.76	1.657	201	4 th
Difficulty	S13	Statistics is not useful to the typical professional.	5.18	1.805	201	18 th
	S16	Statistical thinking is not applicable in my life outside my job.	4.81	1.914	201	33.5 th
	S17	I use statistics in my everyday life.	4.76	1.818	201	36 th
	S21	Statistics conclusions are rarely presented in everyday life.	4.95	2.056	201	28 th
	S25	I am interested in understanding statistical information.	4.88	2.019	201	32 nd
Interest	S33	Statistics is irrelevant in my life.	5.16	1.994	201	20 th
	S6	Statistics formulas are easy to understand.	5.21	1.843	201	17 th
	S8	Statistics is a complicated subject.	5.01	1.786	201	24.5 th
	S22	Statistics is a subject quickly learned by most people.	4.79	1.907	201	35 th
	S24	Learning statistics requires a great deal of discipline.	5.41	1.569	201	11 th
Effort	S30	Statistics involves massive computations.	5.67	1.494	201	5 th
	S34	Statistics is highly technical.	5.17	1.712	201	19 th
	S36	Most people have to learn a new way of thinking to do statistics.	5.36	1.390	201	14 th
	S12	I am interested in being able to communicate statistical information to others.	4.92	1.830	201	30 th
	S20	I am interested in using statistics.	5.09	1.807	201	22 nd

In the item statistics they all have means roughly the same and the scores were taken on the 1-7 point scale.

Standard deviations are also roughly the same and that's why two measure of reliability are corresponding. The

individual summary statistics seems to indicate the students' attitude toward statistics with regard to six components of attitude, i.e. affect, cognitive competence, value, difficulty, interest and effort (Table 5). The first sub-component of attitude was 'affect'. The highest mean score was achieved by item number three (Mean =5.66) while item number four scored the lowest mean score (Mean=4.81) with a mean difference of.81 scores which shows a slight difference between the highest and lowest value of average scores attained by both items. The mean scores for item number 28, item number 19, item number 15, and item number 18 were found to be 5.03, 5.01, 5.00, and 4.92 respectively in descending order which shows roughly the same attitude of respondents over the 1-7 point scale. Furthermore, if we look at the middle value of scales, it seems that the mean scores of all six items are roughly at a slightest distance from the midpoint point 4 which may be taken to apply One Sample t-Test for analyzing the significance difference of mean scores for all six components of attitude. Table 5 shows that the mean scores of all items fall into the positive region of the scale with a slight difference of scores from the middle value of the 1-7 point scale. As far as the variability of scores is concerned, it seems that the average scores of four items were at one standard deviation while average scores of two items were at two standard deviation away from the mean position which depicted that item number 18 and item number 28 showed more variability of attitudes that item number 3, 4, 15, and 19 respectively. The Cronbach Alpha for this component of attitude was 0.759.

Likewise, the highest mean score for the second component 'Cognitive Competence' was achieved by item number 32 (Mean =5.60), item number 10 by the third component 'Value' (Mean=5.76), item number 30 by the fourth component 'Difficulty' (Mean=5.67), item number 29 by the fifth component 'Interest' (Mean=5.59), item number 27 by the sixth component 'Effort' (Mean=6.08) while item number 35, item number 17, item number 22, item number 12, and item number 14 scored the lowest mean score (Mean=4.89, 4.76, 4.79, 4.92, 5.40) with a

mean difference of.71, 1.00,.88,.67,.68 scores which shows a slight difference among the highest and lowest value of average scores attained by these items. It was observed that the mean scores for the items left behind showed roughly the same attitude of respondents over the 1-7 point scale. Furthermore, if we look at the middle value of scales, it seems that the mean scores of all six items are roughly at a slightest distance from the midpoint point 4 which may be taken to apply One Sample t-Test for analyzing the significance difference of mean scores for all six components of attitude. However, it was noted that mean score of item number 31 and item number 27 crossed the sixth point of 1-7 point scale while mean score of 24 items crossed the 5th point and the mean score of 10 items crossed the 4th point on 1-7 point scale. The table shows that the mean scores of all items each subcomponent i.e. affect, cognitive competence, value, difficulty, interest and effort, fell into the positive region with a slight difference of scores from the middle value of the 1-7 point scale. As far as the variability of scores is concerned, it seems that the average scores of 32 items were at one standard deviation away from the mean position while average scores of item number 18, 28, 21, and 25 were at somewhat more than two standard deviation away from the mean position which depicted that these items showed more variability of attitudes. The Cronbach Alpha for this component of attitude was 0.759. Descriptive Statistics of Composite SATS 36 & its Six Components

The fourth objective of the study was evaluate the difference between descriptive statistics of undergraduate, graduate, and postgraduate students in Pakistani sample of public sector universities using Schau's (2003) instrument of Students' Attitude Towards Statistics in present study and the study conducted by Schau (2003). The following table shows the descriptive statistics of the composite SATS 36 and its six subcomponents i.e. Affect, Cognitive Competence, Value, Difficulty, Interest, and Effort in a Likert 1-7 scale.

Table 6

Scale means and standard deviations for attitudes toward statistics in our study (n=201) and as reference, values reported in Schau (2003)

Sub Scale	Mean (Standard deviation)	
	This study	Schau (2003)
Affect	5.2065 (1.28488)	4.03 (1.14)
Cognitive Competence	5.7181 (1.09892)	4.91 (1.09)
Value	5.2261 (1.08624)	4.86 (1.01)
Difficulty	5.3831 (.89771)	3.62 (0.78)
Interest	5.2425 (1.40710)	
Effort	5.6915 (1.12333)	
Total	5.3889	.92500

It was found that all scale means are larger than the neutral value of four. Therefore, students in our sample expressed positive attitudes towards SATS 36 and its

subcomponents Affect, Cognitive Competence, Value, Interest, and Effort. It was also found that means and standard deviations are slightly different with values

reported in Schau (2003) found in a large class of undergraduate U.S. students.

The first research question was "Are attitudes of students toward statistics with regard to six components of attitude, i.e. affect, cognitive competence, value, difficulty, interest and effort are different with respect to the average scores of present study and the study conducted by Schau (2003)?" A descriptive comparison was made between the average scores of both studies with respect to all six components of SATS. The mean score for Affect domain in the present study (Mean=5.21 SD=1.28) was higher than that of Schau (2003) by 0.15 (Mean=4.03 SD=1.14) which shows difference in the attitude of students toward statistics with respect to Affect domain in both studies. The mean score for Affect domain in the present study (Mean=5.72 SD=1.10) was higher than that of Schau (2003) by 0.15 (Mean=4.91 SD=1.09) which shows difference in the attitude of students toward statistics with respect to cognitive competence domain in both studies. The mean score for Value domain in the present study (Mean=5.23 SD=1.09) was higher than that of Schau (2003) by 0.15 (Mean=4.86 SD=1.01) which shows difference in the attitude of students toward statistics with respect to Value domain in both studies. The mean score for Difficulty domain in the present study (Mean=5.38 SD=.90) was higher than that of Schau (2003) by 0.15 (Mean=3.62 SD=.78) which shows difference in the attitude of students toward statistics with respect to Difficulty domain in both studies. The mean score for Interest domain in the present study (Mean=5.24 SD=1.41) and the mean score for Effort domain in the present study (Mean=5.69 SD=1.12) was reported in the positive region of the scale while the mean score of these new components were not yet included by Schau (2003). The comparison of attitude between the present study and the study conducted by Schau (2003) shows slight difference of mean scores with respect to four components of the scale. The difference might be due to the context in which both studies have been conducted or it is due to some other reasons including sample and sample size, population, nature of research design etc.

Factor Analysis

Factor analysis is used in to identify a small number of factors, to explain the patterns of correlations, and to identify factors or underlying variables. Seven methods of factors analysis are available. It is used to remove redundant (highly correlated) variables from the data file with a smaller number of uncorrelated variables. To obtain a factor analysis, the researcher chose from the menu Analyze > Dimension Reduction > Factor and selected the variable for the factor analysis. This method is used to find a linear combination of variables that accounts for variation as much as possible in the original variable and

then finds another component that accounts for variation as much as possible for the second component and is uncorrelated with the previous component and so on to replace the original variables for a few components [59]. The researcher applied the principal components method of extraction out of available methods including unweighted least squares, generalized least squares, maximum likelihood, principal axis factoring, alpha factoring, and image factoring. According to IBM Corporation, [59], the principal component analysis is used when a correlation matrix is singular and to form uncorrelated linear combinations of the observed variables to explain maximum variance and progressively smaller portions of the variance of successive components uncorrelated with each other. The correlation matrix is useful if variables are measured on different scales while that of covariance matrix is useful when factor analysis is applied on multiple groups with different variances for each variable. The components are extracted with the help of eigenvalues or by retaining a specific number of factors. The unrotated factor solution displays unrotated factor eigenvalues, communalities, and loadings for factor solution while scree plot is used to determine the number of factors with the help of steep slope and the gradual trailing of the rest. There are five available methods for factor rotation including varimax, promax, direct oblimin, equamax, and quartimax. The researcher applied varimax method to minimize the number of variables that have high loadings on each other. Furthermore, rotated solution and factor loading plot tabs were also checked to obtain a rotated solution. The researcher chose regression method for factor analysis scores to estimate factor score coefficients in the presence of other alternative methods for calculating factor scores such as regression, Bartlett, and Anderson-Rubin. The coefficient display format allows a researcher to control aspects of the output matrices by suppressing coefficients and the absolute value was adjusted to below.30 [59]. The researcher chose Analyze > Dimension Reduction > Factor from the menu to run a principal components factor analysis and selected variables for factor analysis. After that, the researcher clicked on the extraction button and selected principal component analysis, correlation matrix, unrotated factor solution, scree plot, fixed number of factors from extraction menu; varimax method, rotated solution, and loading plot (s) from rotation menu; regression method and display factor score coefficient matrix from factor score menu; and suppress small coefficient from option menu to run the factor analysis procedure. The communalities are discussed in the below-mentioned table to indicate the amount of variance in each variable that is accounted for.

Table 7
Communalities for attitudes toward statistics in our study (n = 201)

No.	Statements of STAS 36	Initial	Extraction
S1	I tried to complete all of my statistics assignments.	1.000	.550
S2	I worked hard in my statistics course.	1.000	.508
S3	I like statistics.	1.000	.462
S4	I feel insecure when I have to do statistics problems.	1.000	.427
S5	I have trouble understanding statistics because of how I think.	1.000	.390
S6	Statistics formulas are easy to understand.	1.000	.495
S7	Statistics is worthless.	1.000	.402
S8	Statistics is a complicated subject.	1.000	.163
S9	Statistics should be a required part of my professional training.	1.000	.440
S10	Statistical skills will make me more employable	1.000	.508
S11	I have no idea of what's going on in this statistics course.	1.000	.547
S12	I am interested in being able to communicate statistical information to others.	1.000	.520
S13	Statistics is not useful to the typical professional.	1.000	.472
S14	I tried to study hard for every statistics test.	1.000	.535
S15	I get frustrated going over statistics tests in class.	1.000	.422
S16	Statistical thinking is not applicable in my life outside my job.	1.000	.334
S17	I use statistics in my everyday life	1.000	.259
S18	I am under stress during statistics class.	1.000	.488
S19	I enjoy taking statistics courses.	1.000	.648
S20	I am interested in using statistics.	1.000	.628
S21	Statistics conclusions are rarely presented in everyday life.	1.000	.223
S22	Statistics is a subject quickly learned by most people.	1.000	.404
S23	I am interested in understanding statistical information.	1.000	.562
S24	Learning statistics requires a great deal of discipline.	1.000	.590
S25	I will have no application for statistics in my profession.	1.000	.417
S26	I make a lot of math errors in statistics.	1.000	.270
S27	I tried to attend every statistics class session.	1.000	.474
S28	I am scared by statistics.	1.000	.531
S29	I am interested in learning statistics.	1.000	.612
S30	Statistics involves massive computations.	1.000	.364
S31	I can learn statistics.	1.000	.522
S32	I understand statistics equations.	1.000	.573
S33	Statistics is irrelevant in my life.	1.000	.379
S34	Statistics is highly technical.	1.000	.447
S35	I find it difficult to understand statistical concepts.	1.000	.398
S36	Most people have to learn a new way of thinking to do statistics.	1.000	.280

Table 7 indicated the initial communalities estimates of the variance in each variable accounted for by all factors equal to 1.0 for correlation analyses have high, average, and low values which means that extracted components represents variables well while another component may be extracted in case of low communalities may be extracted.

Furthermore, the total variance explained is indicated in the below-mentioned table representing the eigenvalues in the first section and extraction sums of squared loadings in the second section with the help of rotated components, extracted components, and the initial solution.

Table 8
Total Variance Explained for attitudes toward statistics in our study (n = 201)

No.	Statements of STAS 36	Initial Eigenvalues			Extraction Sums of Squared Loadings		
		Total	% of Variance	Cumulative %	Total	% of Variance	Cumulative %
S1	I tried to complete all of my statistics assignments.	8.060	22.388	22.388	8.060	22.388	22.388
S2	I worked hard in my statistics course.	1.964	5.456	27.844	1.964	5.456	27.844
S3	I like statistics.	1.766	4.905	32.749	1.766	4.905	32.749

S4	I feel insecure when I have to do statistics problems.	1.616	4.489	37.238	1.616	4.489	37.238
S5	I have trouble understanding statistics because of how I think.	1.428	3.968	41.206	1.428	3.968	41.206
S6	Statistics formulas are easy to understand.	1.409	3.914	45.119	1.409	3.914	45.119
S7	Statistics is worthless.	1.368	3.801	48.920			
S8	Statistics is a complicated subject.	1.220	3.389	52.309			
S9	Statistics should be a required part of my professional training.	1.165	3.236	55.546			
S10	Statistical skills will make me more employable	1.148	3.190	58.736			
S11	I have no idea of what's going on in this statistics course.	1.087	3.018	61.754			
S12	I am interested in being able to communicate statistical information to others.	.990	2.749	64.503			
S13	Statistics is not useful to the typical professional.	.921	2.560	67.062			
S14	I tried to study hard for every statistics test.	.886	2.462	69.524			
S15	I get frustrated going over statistics tests in class.	.835	2.320	71.844			
S16	Statistical thinking is not applicable in my life outside my job.	.824	2.289	74.133			
S17	I use statistics in my everyday life	.773	2.147	76.280			
S18	I am under stress during statistics class.	.721	2.002	78.282			
S19	I enjoy taking statistics courses.	.698	1.938	80.221			
S20	I am interested in using statistics.	.658	1.827	82.048			
S21	Statistics conclusions are rarely presented in everyday life.	.632	1.755	83.802			
S22	Statistics is a subject quickly learned by most people.	.603	1.676	85.479			
S23	I am interested in understanding statistical information.	.550	1.527	87.005			
S24	Learning statistics requires a great deal of discipline.	.523	1.454	88.459			
S25	I will have no application for statistics in my profession.	.480	1.334	89.792			
S26	I make a lot of math errors in statistics.	.450	1.250	91.043			
S27	I tried to attend every statistics class session.	.432	1.201	92.243			
S28	I am scared by statistics.	.411	1.143	93.386			
S29	I am interested in learning statistics.	.386	1.073	94.459			
S30	Statistics involves massive computations.	.366	1.016	95.475			
S31	I can learn statistics.	.334	.927	96.402			
S32	I understand statistics equations.	.323	.896	97.298			
S33	Statistics is irrelevant in my life.	.305	.847	98.145			
S34	Statistics is highly technical.	.249	.691	98.836			
S35	I find it difficult to understand statistical concepts.	.224	.623	99.459			
S36	Most people have to learn a new way of thinking to do statistics.	.195	.541	100.000			

Extraction Method: Principal Component Analysis.

Table 8 indicates the eigenvalue or amount of variance expressed in terms of percentage accounted for by each component to the total variance from the initial eigenvalue of 8.060 (22.39%) of first component to the eigenvalue.195 (.54%) of the last component. First eleven factors have eigenvalues greater than 1 while rest of the components has eigenvalues less than 1. It means that first eleven components form the extracted solution while in the second section of the table, it has been depicted that nearly 45% of the variability has been explained by the selected components with 55% loss of information as it

was aimed that six components are to be extracted for factor analysis of SATS 36 because the original version contained the same number of components. The extraction sums of squared loadings shows that six components have been extracted and 45.12% variability has been accounted for these components which starts from the variability of first component (22.39%) and ends at the variability of sixth component (3.91%). The optimal number of components was determined with the help of the below-mentioned scree plot to represent the eigenvalue of each component in the initial solution.

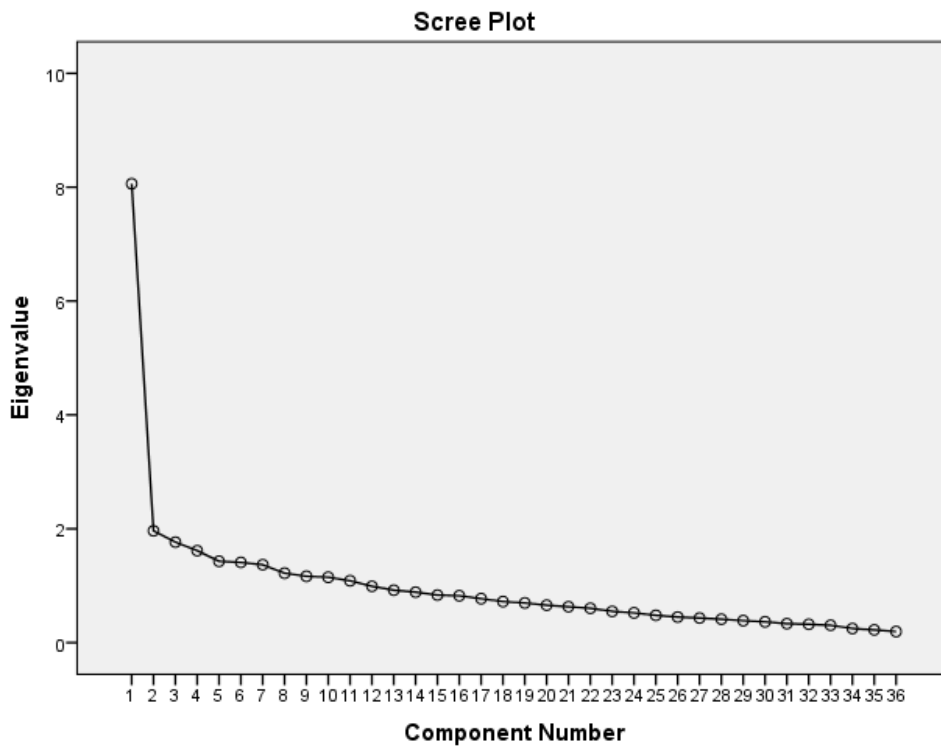

Graph 1
Scree plot for attitudes toward statistics in our study (n = 201)

The graph represents that only two components have been indicated on the steep slope while all other components which have been extracted on the shallow slope contribute little to this solution. It means that we can

use the first two components for an easy choice. The rotated component matrix is indicated in the below-mentioned table to determine what the components actually represent.

Table 9
Rotated Component Matrix for attitudes toward statistics in our study (n = 201)

No.	Statements of STAS 36	Component					
		1	2	3	4	5	6
S1	I tried to complete all of my statistics assignments.	.457	.304	.465			
S2	I worked hard in my statistics course.	.583					
S3	I like statistics.	.580					
S4	I feel insecure when I have to do statistics problems.			.386	-.400		
S5	I have trouble understanding statistics because of how I think.				.329		.497
S6	Statistics formulas are easy to understand.	.575		-.380			
S7	Statistics is worthless.	.595					
S8	Statistics is a complicated subject.						
S9	Statistics should be a required part of my professional training.	.554					
S10	Statistical skills will make me more employable	.518					-.314
S11	I have no idea of what's going on in this statistics course.	.585	-.410				
S12	I am interested in being able to communicate statistical information to others.	.591					
S13	Statistics is not useful to the typical professional.	.446	-.405				
S14	I tried to study hard for every statistics test.	.572	.341				
S15	I get frustrated going over statistics tests in class.			.343	.473		
S16	Statistical thinking is not applicable in my life outside my job.	.344					
S17	I use statistics in my everyday life			.326			.323
S18	I am under stress during statistics class.	.440	-.463				
S19	I enjoy taking statistics courses.	.761					
S20	I am interested in using statistics.	.686					-.308
S21	Statistics conclusions are rarely presented in everyday life.						

S22	Statistics is a subject quickly learned by most people.	.478			
S23	I am interested in understanding statistical information.	.731			
S24	Learning statistics requires a great deal of discipline.	.492		.517	
S25	I will have no application for statistics in my profession.	.449	.360		
S26	I make a lot of math errors in statistics.				-.458
S27	I tried to attend every statistics class session.	.551			
S28	I am scared by statistics.	.531	-.380		
S29	I am interested in learning statistics.	.745			
S30	Statistics involves massive computations.		.413		-.362
S31	I can learn statistics.	.558	-.374		
S32	I understand statistics equations.	.514	-.334		.361
S33	Statistics is irrelevant in my life.	.451			
S34	Statistics is highly technical.			-.438	.308
S35	I find it difficult to understand statistical concepts.			.511	
S36	Most people have to learn a new way of thinking to do statistics.				

Extraction Method: Principal Component Analysis.

a. 6 components extracted.

Table 9 indicated values of correlation between six components which have been extracted for the final solution with respect to each factor suppressing coefficient value to below .30. It means that only those values of correlations between six components and 36 factors have been extracted which have coefficient value equal or greater than .30. Both positive and negative correlation values have been reported. It is obvious that the factor solution indicated in Table 9 may not confirm the number of components extracted in a study of SATS 36 conducted

by Schau as well as the inclusion of factors in each component is also not in accordance with that of Schau's.

Inter-Item Correlation Matrix

The fifth objective of the study was to determine the Inter-Item Correlation of undergraduate, graduate, and postgraduate students in Pakistani sample of public sector universities using Schau's (2003) instrument of Students' Attitude towards Statistics. Following table depicts this matrix for the students' attitude towards statistics.

Table 10

Inter-Item Correlation Matrix for the students' attitude towards statistics (SATS 36) in a Pakistani sample containing six factors

Sub Components		S3, S4, S15, S18, S19, S28							
Affect		1.000							
	S3,	.105	1.000						
	S4,	.070	-.019	1.000					
	S15,	.226	-.098	.226	1.000				
	S18,	.390	-.074	.029	.363	1.000			
	S19,	.191	-.092	.014	.293	.438	1.000		
Cognitive Competence									
	S5,	.102	1.000						
	S11,	-.050	-.071	1.000					
	S26,	.041	.240	-.038	1.000				
	S31,	.131	.226	-.104	.571	1.000			
	S32,	.165	.025	-.105	.072	.079	1.000		
Value									
	S7,	.284	.244	.281	.160	-.060	.066	.290	.274
	S9,	.284	.488	.109	.110	-.104	.039	.176	.242
	S10,	.244	.488	1.000	.155	.206	-.025	.089	.192
	S13,	.281	.109	.155	1.000	.254	-.041	.116	.309
	S16,	.160	.110	.206	.254	1.000	.117	.127	.231
	S17,	-.060	-.104	-.025	-.041	.117	1.000	.104	.019
	S21,	.066	.039	.089	.116	.127	.104	1.000	.176
	S25,	.290	.176	.192	.309	.231	.019	.176	1.000
S33								.358	

		.274	.242	.269	.245	.235	-.109	.086	.358	1.000
					S6, S8, S22, S24, S30, S34, S36					
		1.000	-.036	.391	.313	.064	.193	.109		
Difficulty	S6,	-.036	1.000	-.189	-.021	-.150	-.012	-.001		
	S8,	.391	-.189	1.000	.237	-.088	.133	.151		
	S22,	.313	-.021	.237	1.000	.101	.356	.231		
	S30,	.064	-.150	-.088	.101	1.000	.104	-.002		
	S34,	.193	-.012	.133	.356	.104	1.000	.168		
	S36	.109	-.001	.151	.231	-.002	.168	1.000		
					S12, S20, S23, S29					
Interest	S12,		1.000	.536		.413		.457		
	S20,		.536	1.000		.541		.556		
	S23,		.413	.541		1.000		.645		
	S29		.457	.556		.645		1.000		
					S1, S2, S14, S27					
Effort	S1,		1.000	.555		.308		.252		
	S2,		.555	1.000		.500		.215		
	S14,		.308	.500		1.000		.362		
	S27		.252	.215		.362		1.000		

Then we get the inter-item correlation matrix which is very useful for understanding the scale regarding six components of attitude, i.e. affect, cognitive competence, value, difficulty, interest and effort. The correlations are not really very high. For the first subcomponent 'Affect', the inter-correlation ($r = .019$, $r = .098$, $r = .074$, and $r = .092$) of item number 15, 18, 19, 28 with item number 4 are actually negative but all these items should be inter-correlated with each other positively because they are measuring supposedly the same thing but this pattern of correlation is suggesting that the items are not really and totally measuring the same phenomenon. Usually, the items should be in the $r = .3$ and $r = .5$ range because a lot of consideration is given in this range of correlation in which you can easily get a pretty good scale for attaining a better level of internal consistency. Likewise, if we look at the positive values of Inter-item correlation matrix, it is obvious that the inter-correlation between items 19 and item 3; item 19, item 18, and item 28 fall within the range of correlation pattern while rest of the Inter-item correlation matrix indicates that they do not meet the minimum criteria. Therefore, it is concluded that the aforementioned correlation matrix mostly have poor correlation values resulting in low estimates of internal consistency. While there is a lot of information to be gleaned from looking at correlations but a single summary statistic earlier analyzed can tell us the reliability of our survey but the most common way of measuring reliability estimates of the survey is Cronbach's alpha. The Cronbach's Alpha for this component of attitude was 0.759 but ideally with the help of higher correlations values of $r = .8$ and $r = .9$, you can get the higher level of reliability estimates.

For the second subcomponent 'Cognitive Competence', the inter-correlation ($r = .050$, $r = .071$, $r = .038$, $r = .104$, and $r = .105$) of item number 5, 11, 31, 32, 35 with item number 26, for the third subcomponent 'Value', the inter-correlation ($r = .060$, $r = .104$, $r = .025$, $r = .041$, and $r = .109$) of item number 7, 9, 10, 13, 33 with item number 17, for the fourth subcomponent 'Difficulty', the inter-correlation ($r = .036$, $r = .189$, $r = .021$, $r = .150$, $r = .012$, and $r = .001$) of item number 6, 22, 24, 30, 34, 36 with item number 8 as well as the inter-correlation of item number 36 with item number 30 are actually negative while there was no negative value of correlation in the fifth component 'Interest' and the sixth component 'Effort' but all these items should be inter-correlated with each other positively because they are measuring supposedly the same thing but this pattern of correlation is suggesting that the items are not really and totally measuring the same phenomenon. Usually, the items should be in the $r = .3$ and $r = .5$ range because a lot of consideration is given in this range of correlation in which you can easily get a pretty good scale for attaining a better level of internal consistency.

Likewise, if we look at the positive values of Inter-item correlation matrix, it is obvious that the inter-correlation of item number 32 with item number 31 ($r = .571$) in the second subcomponent 'Cognitive Competence, the inter-correlation of item number 10 with item number 9 ($r = .488$); item number 13 with item number 25 ($r = .309$); item number 25 with item number 33 ($r = .358$) in the third component 'Value', the inter-correlation of item number 22 and item number 24 with item number 6 ($r = .391$ & $r = .313$); item number 34 with item number 24 ($r = .356$) in the fourth subcomponent 'Difficulty', the inter-correlation of item number 20, 23, and 29 with item number 12 ($r =$

.536, $r = .413$ & $r = .457$); item number 20 with item number 23 and item number 29 ($r = .541$); item number 23 with item number 29 ($r = .645$) in the fifth component 'Interest' and the inter-correlation of item number 1 with item number 2 and 14 ($r = .555$ & $r = .308$); item number 14 with item number 2 ($r = .500$); item number 27 with item number 14 ($r = .362$) fall within or above the range of correlation pattern while rest of the Inter-item correlation matrix indicated that they do not meet the minimum criteria. Therefore, it is concluded that the aforementioned correlation matrix mostly have poor correlation values resulting in low estimates of internal consistency. While there is a lot of information to be gleaned from looking at correlations but a single summary statistic earlier analyzed can tell us the reliability of our survey but the most common way of measuring reliability estimates of the

survey is Cronbach's alpha but ideally with the help of higher correlations values of .8 and .9, you can get the higher level of reliability estimates.

Correlation Matrix

The sixth objective of the study was to examine the Correlation Matrix of undergraduate, graduate, and postgraduate students in Pakistani sample of public sector universities using Schau's (2003) instrument of Students' Attitude Towards Statistics. The results obtained from the correlation matrix are shown in Table 11; we observe the behavior of each variable with respect to others. The criteria for determining low correlation is the higher number, lower versus higher determining the correlation, then one can predict the degree of inter-correlation between the variables.

Table 11
Factor inter-correlations for the six factor Model

Scale	SATS	Affect	Cog. Competence	Value	Difficulty	Interest	Effort
SATS	1						
Affect	.549(**)	1					
Cog. Competence	.290(**)	-.011	1				
Value	.493(**)	.342(**)	-.023(**)	1			
Difficulty	.655(**)	.135	.237(**)	.053	1		
Interest	.530(**)	-.073	.255(**)	-.087	.385(**)	1	
Effort	.591(**)	.036	.316(**)	-.055	.418(**)	.578(**)	1

**Pearson correlation coefficients was significant at $p < 0.01$.

The factor inter-correlations for the six factor model are shown in Table 11. Correlation coefficients between the Attitudes toward statistics sub-scales were also calculated. As presented in Table 11, the inter-correlations of the Attitudes toward Statistics factors suggested the pattern of interrelationships. In the above table we see that the correlations are high with respect to the values of composite scale and its respective sub components i.e. affect ($r = .549$ $p < 0.01$), cognitive competence ($r = .290$ $p < 0.01$), value ($r = .493$ $p < 0.01$), difficulty ($r = .655$ $p < 0.01$), interest ($r = .530$ $p < 0.01$), and effort ($r = .591$ $p < 0.01$) indicating a high degree of inter-correlation between the variables except that of cognitive competence; however, it shows a positive correlation between all possible pairs of sub components except: cognitive competence vs. affect ($r = -.011$); interest vs. affect ($r = -.073$); value vs. cognitive competence ($r = -.023$), interest vs. value ($r = -.087$), and effort vs. value ($r = -.055$), this should be taken with caution when wording the

conclusions. Just to mention some examples of significant correlations (the highest) should be correlated: value vs. affect ($r = .342$), effort vs. cognitive competence ($r = .316$), interest vs. difficulty ($r = .385$), effort vs. difficulty ($r = .418$), and effort vs. interest ($r = .578$) and the rest of the variables are presented in the order of ($r = .135$, $r = .036$, $r = .237$, $r = .255$, and $r = .053$) their respective correlations between the variables involved in this study. It was noted that the moderate correlations between factors suggested notable discriminant validity between these related aspects of students' attitudes towards statistics but the strong correlation between the interest and effort factors may suggest a lack of discriminant validity.

Item-Total Statistics

The seventh objective of the study was to interpret the Item-Total Statistics of undergraduate, graduate, and postgraduate students in Pakistani sample of public sector universities using Schau's (2003) instrument of Students' Attitude Towards Statistics. The following table depicts this sort of statistics for SATS 36 and its subcomponents.

Table 12
Item-Total Statistics for the students' attitude towards statistics (SATS 36) in a Pakistani sample containing six factors

Sub Components	Items	Scale Mean if Item Deleted	Scale Variance if Item Deleted	Corrected Item-Total Correlation	Squared Multiple Correlation	Cronbach's Alpha if Item Deleted
Affect	S3	24.78	28.475	.362	.182	.423
	S4	25.62	36.056	-.070	.038	.593
	S15	25.43	31.307	.119	.057	.533
	S18	25.52	23.741	.397	.211	.381

	S19	25.42	25.004	.460	.331	.358
	S28	25.40	25.461	.328	.216	.427
Cognitive Competence	S5	26.91	19.166	.160	.050	.272
	S11	26.95	16.758	.186	.078	.247
	S26	27.20	22.953	-.133	.024	.468
	S31	26.01	18.250	.366	.343	.165
	S32	26.59	16.543	.330	.350	.143
Value	S35	27.31	18.904	.080	.041	.334
	S7	40.63	58.414	.379	.193	.583
	S9	40.94	60.871	.320	.281	.598
	S10	40.31	60.336	.400	.286	.582
	S13	40.89	60.138	.356	.176	.590
	S16	41.26	59.283	.353	.146	.590
	S17	41.31	70.656	-.020	.057	.673
	S21	41.12	62.916	.191	.052	.632
	S25	41.19	55.924	.443	.229	.565
	S33	40.91	57.376	.398	.225	.578
Difficulty	S6	31.40	21.402	.378	.215	.281
	S8	31.60	30.581	-.128	.069	.549
	S22	31.82	23.558	.219	.228	.378
	S24	31.20	22.283	.439	.225	.267
	S30	30.95	28.972	.003	.066	.473
	S34	31.44	23.058	.320	.147	.323
	S36	31.25	26.170	.221	.071	.382
Interest	S12	16.05	19.392	.555	.328	.804
	S20	15.88	18.159	.666	.444	.750
	S23	15.60	19.602	.645	.467	.762
	S29	15.38	18.548	.673	.491	.747
Effort	S1	16.94	13.211	.483	.327	.630
	S2	17.31	12.024	.573	.429	.572
	S14	17.36	11.181	.524	.318	.602
	S27	16.68	13.688	.353	.154	.707

Then we look at the item total statistics and particular the corrected item-Total Correlation. These are basically the correlations between the items and a composite score of all the other remaining items so it is basically the scale scores minus the item of interest its correlation with the item so it is corrected because the item is not included in the scale under this correlation. We got nice moderate correlations ($r = .362$, $r = .397$, $r = .460$, and $r = .328$) for item number 3, 18, 19 and 28 in the first subcomponent 'Affect'; nice moderate correlations ($r = .366$ and $r = .330$) for item number 31 and item number 32 in the second subcomponent 'Cognitive Competence', nice moderate correlations ($r = .379$, $r = .320$, $r = .400$, $r = .356$, $r = .353$, $r = .443$, and $r = .398$) for item number 7, 9, 10, 13, 16, 25, and 33 in the third subcomponent 'Value'; nice moderate correlations ($r = .378$, $r = .439$, and $r = .320$) for item number 6, 24, and 34 in the fourth subcomponent 'Difficulty'; very nice correlations ($r = .555$, $r = .666$, $r = .645$, and $r = .673$) for item number 12, 20, 23, and 29 in the fifth subcomponent 'Interest', and nice moderate

correlations ($r = .483$, $r = .573$, $r = .524$, and $r = .353$) for item number 1, 2, 14, and 27 in the sixth subcomponent 'Effort'. Ideally we have corrected item total correlation in the range $r = .3$ to $r = .7$. We also got some low correlations in case of item number 4 ($r = -.070$), item number 15 ($r = .119$), item number 5 ($r = .160$), item number 11 ($r = .186$), item number 26 ($r = -.133$), item number 35 ($r = .080$), item number 17 ($r = -.020$), item number 21 ($r = .191$), item number 8 ($r = -.128$), item number 22 ($r = .219$), item number 30 ($r = .003$), and item number 36 ($r = .221$). It was observed that item number 4, item number 26, item number 17, and item number 8 produced a very poor but minus value of corrected item-total correlation while item number 15, item number 5, item number 11, item number 35, item number 21, item number 22, item number 30, and item number 36 produced a very poor but positive value of corrected item total correlation by evaluating the Pearson correlation across all individuals. This small item-correlation shows that the items are not measuring the same construct measured by

the other items. It is due to the correlation value less than $r = 0.2$ or $r = 0.3$ which indicates that the corresponding item does not correlate with the scale overall, therefore, items may be dropped from the scale. Therefore, it may be concluded that item 4 and item 15 had improved the Cronbach's alpha (.593 and .533) in case of their elimination from the first subcomponent 'Affect'; item number 26 had improved the Cronbach's Alpha (.468) in case of its elimination from the second subcomponent 'Cognitive Competence'; item number 17 had improved the Cronbach's Alpha (.673) in case of its elimination from the third subcomponent 'Value'; item number 8 had improved Cronbach's Alpha (.549) in case of its elimination from the fourth subcomponent 'Difficulty' because these items were inconsistent with the averaged behavior of the rest of items, and thus had been discarded

to improve the Cronbach's Alpha in each subcomponent. It may be asked that the value of Cronbach's Alpha may be improved in case of eliminating garbage from this component prior to determining the factors that represent the construct by improving reliability estimates in each subcomponent as well as in the case of composite reliability estimates. It is assumed that in a reliable measure, all items should correlate well with the average of the others.

Scale Statistics

The eighth objective of the study was to summarize the Scale Statistics of undergraduate, graduate, and postgraduate students in Pakistani sample of public sector universities using Schau's (2003) instrument of Students' Attitude Towards Statistics. The following table represents this sort of statistics for SATS 36 and its subcomponents.

Table 13
Scale Statistics for the students' attitude towards statistics (SATS 36) in a Pakistani sample containing six factors

Sub Components	Mean	Variance	Std. Deviation	N of Items
Affect	30.43	37.167	6.096	6
Cognitive Competence	32.19	23.787	4.877	6
Value	46.07	73.365	8.565	9
Difficulty	36.61	31.249	5.590	7
Interest	20.97	31.679	5.628	4
Effort	22.76	20.213	4.496	4

Table 13 has the values for total scale with regard to six components of attitude, i.e. affect, cognitive competence, value, difficulty, interest and effort. The total 7-point scale consists of 36 items and its responses ranged from 36 to 252. It means that the lowest score of mean with respect to total scale will be 36 while the highest level of responses achieves a total mean value 252. If someone strongly disagrees with every single question, they would attain 36 scores while in case of answering 7 to every single question, their scores would be 252. Likewise, the scale has a specific lower and upper values for each sub scale, i.e. affect, cognitive competence, value, difficulty, interest, and effort. As far as sub components are concerned, the lowest, middle, and highest values of mean scores with regard to affect (lowest = 6 middle = 24 highest = 42), cognitive competence (lowest = 6 middle = 24 highest = 42), value (lowest = 9 middle = 36 highest = 63), difficulty (lowest = 7 middle = 28 highest = 49), interest (lowest = 4 middle = 16 highest = 28) and effort (lowest = 4 middle = 16 highest = 28) were used to as range scores to assess the level of attitude of people. It is the possible scale range for the opinions of people. The table shows that average is given by the means with regard to six components of attitude i.e. affect (Mean = 30.43 V = 37.167 SD = 6.096), cognitive competence (Mean = 32.19 V = 23.787 SD = 4.877), value (Mean = 46.07 V = 73.365 SD = 8.565), difficulty (Mean = 36.61 V = 31.249 SD = 5.590), interest (Mean = 20.97 V = 31.679 SD = 5.628) and effort (Mean = 22.76 V = 20.213 SD = 4.496) are 30.43 alongwith its variance and standard deviation. All

mean values of the six components depicts they lie above than the middle level of the respective sub scale. Therefore, it depicts students' attitudes towards statistics are in positive direction with a slight difference of mean.

V. DISCUSSION

As we see from Cronbach's Alpha and correlations in the Pakistani version of SATS 36, it has shown a difference in reliability estimates and descriptive statistics of the data in the present study and the study conducted by Schau (2003). The reason for the discomfort of statistics students was measured with a Pakistani sample of Public Sector University. As to comparison of our Pakistani context and the original study conducted by Schau (2003), there were few discrepancies regarding the difference of reliability estimates. We can say that these discrepancies in the reliability estimates are due to number of factors that does not allow measurements exactly replicable or repeatable. The differences in reliability estimates may be due to variation in performance within a test or it may be due to error of instrumentation that may cause variation in performance on different forms of a test [56]. Error due to item sampling is also a major source of difference in reliability estimates but it is entirely predictable with the help of coefficient alpha. Errors might be occurred due to skipping a question inadvertently, marking answers incorrectly (clerical errors), misinterpreting test instructions, systematic differences in content of the two tests, respondents' change with regard to the attribute being measured, and guessing on a test [54]. Nunnally [56] argued that correlations are allowed to be slightly lower

than would be predicted from the correlations among items within tests and tests should be thought of as random samples. He suggested that reliabilities of .70 or higher are sufficient but increasing reliabilities much beyond .80 are often wasteful of time and funds. It requires much effort at standardization to obtain a higher reliability of .90. He recommended that a reliability of at least .90 is desirable where important decisions are made with respect to specific test scores because a great deal depends on the exact score made by a person on a test. Nunnally [56] proposed that you can get reliability improved easily by training the raters, making test instructions understandable, making the rules for scoring as obvious as possible, writing items clearly and making the test longer (adding more items). Furthermore, some precautionary measures should be adopted in this regard as the longer tests are more likely to cause fatigue and boredom in test takers which can reduce the consistency of accurate responding [53].

The present study shows how statistics affect, cognitive competence, value, difficulty, interest, and effort help to understand the students' attitude toward mathematics and technology. The present study may be replicated with a larger sample as well as with different groups of population to validate the results of SATS scale in measuring students' attitude towards statistics. It is also important to point out, the results of the research have a theoretical implication and the construct has practical significance for all stakeholders of teaching and learning process. It is suggested that work should be done on the relationships between students' attitude towards statistics and their academic achievement and collecting data at different time period in the semester system. In addition, the translated version of SATS 36 may produce fruitful results for reliability estimates as few respondents were confused to interpret some of statements. Factors identified by Schau (2003) in SATS 36 may also be re-examined and exploratory factor analysis as well as confirmatory factor analysis would be applied to a larger Pakistani sample. The results are useful for higher education institutions in Pakistan in formulating policies regarding course outlines and providing necessary infrastructure for the introductory courses to be taught as per standard parameters. The study can help curriculum planners to think over the advanced teaching strategies and use of information technology in the introductory courses in order to strengthen the student's attitude toward statistics. This research is limited to only one sector of public university students, therefore, it is important to develop future research that considers other public and private universities and compare the attitude toward statistics are different with respect to the university, gender, residential status, nature of program, financial support, socioeconomic status of students, and against several other demographic variables, therefore, it is

recommended that this study should be replicated by prospective scholars and researchers of educational background. The results of the present study shows that students have positive attitudes towards statistics but the responded did not give enriched views as they consider it an obstacle, therefore, the educational policymakers should concentrated on this point for the betterment of teacher education programs. New data should be obtained for a larger numbers of students. The results of present study needs to be reviewed so that teachers and students realize the importance of statistics course as it is mandatory in various undergraduate, graduate, and postgraduate programs.

Acknowledgment

The authors would like to acknowledge Shaffaq Yousaf, Muhammad Amanullah, Maria Saima Jabir, Waqas Akram, and Sadiq Hussain for their assistance with the data analysis.

Declaration of Conflicting Interests

The author(s) declared no potential conflicts of interest with respect to the research, authorship, and/or publication of this article.

Funding

The author(s) received no financial support for the research, authorship, and/or publication of this article.

REFERENCE

- [1] Waters, L. K., Martelli, T. A., Zakrajsek, T., & Popovich, P. M. (1998). *Attitudes toward statistics: An evaluation of multiple measures. Educational and Psychological Measurement, 48*, 513–516. doi:10.1177/0013164488482026
- [2] Gal, I and Ginsburg, L. (1994). "The Role of Beliefs and Attitudes in Learning Statistics: Towards an Assessment Framework". *Journal of Statistics Education [Online]*, 2 (2). (<http://www.amstat.org/publications/jse/v2n2/gal.html>).
- [3] Schau, C., Stevens, J., Dauphinee, T. L., & DelVecchio, A. (1995). *The development and validation of the Survey of Attitudes toward Statistics. Educational and Psychological Measurement, 55*(5), 868-875.
- [4] Schau, C. (2005). The survey of attitudes towards statistics (SATS) ©. Retrieved on May, 2014 at <http://www.evaluationandstatistics.com>
- [5] Giesbrecht, N. (1996). "Strategies for Developing and Delivering Effective Introductory Level Statistics and Methodology Courses" Alberta, Canada. (ERIC Document Reproduction Service No. ED393 668).
- [6] Cashin, S.E. and Elmore, P.B. (1997). "Instruments Used to Assess Attitudes Toward Statistics: A Psychometric Evaluation". Paper Presented at the

- annual meeting of the American Educational Research Association, Chicago. Ill.*
- [7] Chiesi, F., & Primi, C. (2009). *Assessing statistics attitudes among college students: Psychometric properties of the Italian version of the Survey of Attitudes Toward Statistics (SATS)*. *Learning and Individual Differences, 19*(2), 309–313.
- [8] Gal, I., Ginsburg, L., & Schau, C. (1997). *Monitoring attitudes and beliefs in statistics education*. In I. Gal & J. B. Garfield (Eds.), *The assessment challenge in statistics education* (pp. 37–51). Amsterdam: IOS Press.
- [9] Finney, S. J., & Schraw, G. (2003). *Self-efficacy beliefs in college statistics courses*. *Contemporary Educational Psychology, 28*(2), 161–186.
- [10] Leong, J. L. (2006). *High school students' attitudes and beliefs regarding statistics in a service-learning based statistics course* (Unpublished doctoral dissertation). Georgia State University, Georgia.
- [11] Barton, A.C. (2000). *Crafting multicultural science education with preservice teachers through service-learning*. *Journal of Curriculum Studies, Volume 32*(6), pp. 797-820.
- [12] Furinghetti, F. and Pehkonen, E. (2002). *Rethinking characterizations of beliefs*. In: G. Leder, E. Pehkonen, and G. Toerner (eds.), *Beliefs: A Hidden Variable in Mathematics Education?* Kluwer Academic Publishers, pp. 39-58.
- [13] Carnell, L. J. (2008). *The effect of a student-designed data collection project on attitudes toward statistics*. *Journal of Statistics Education, 16*(1). [Online: <http://www.amstat.org/publications/jse/v16n1/carnell.html>].
- [14] Keeler, C. M., & Steinhorst, R. K. (1995). *Using small groups to promote active learning in the introductory statistics course: A report from the field*. *Journal of Statistics Education, 3*(2). [Online: <http://www.amstat.org/publications/jse/v3n2/keeler.html>].
- [15] Mills, J. (2004). *Students' attitudes toward statistics: Implications for the future*. *College Student Journal, 38*(3), 349–362.
- [16] Shultz, K. S., & Koshino, H. (1998). *Evidence of reliability and validity for Wise's Attitude Toward Statistics scale*. *Psychological Reports, 82*(1), 27–31.
- [17] Suanpang, P., Petocz, P., & Kalceff, W. (2004). *Student attitudes to learning business statistics: Comparison of online and traditional methods*. *Educational Technology & Society, 7*(3), 9–20.
- [18] Cashin, S. E., & Elmore, P. B. (2005). *The Survey of Attitudes Toward Statistics scale: A construct validity study*. *Educational and Psychological Measurement, 65*(3), 1–16.
- [19] Roberts, D. M., & Saxe, J. E. (1982). *Validity of a statistics attitude survey: A follow-up study*. *Educational and Psychological Measurement, 42*(3), 907–912.
- [20] Roberts, D. M., & Bilderback, E. W. (1980). *Reliability and Validity of Statistics Attitude Survey*. *Educational and Psychological Measurement, 40*, 235-238.
- [21] Wise, S. L. (1985). *The Development and Validation of a Scale Measuring Attitudes Toward Statistics*. *Educational and Psychological Measurement, 45*, 401-405.
- [22] Garfield, J., Hogg, B., Schau, C., & Whittinghill, D. (2002). *First courses in statistical science: The status of educational reform efforts*. *Journal of Statistics Education, 10*(2). [Online] www.amstat.org/publications/jse/v10n2/garfield.html).
- [23] Zeidner, M. (1991). *Statistics and mathematics anxiety in social students: Some interesting parallels*. *British Journal of Educational Psychology, 61*, 319–328.
- [24] Hatcher, L. (1994). *A step-by-step approach to using the SAS system for factor analysis and structural equation modeling*. Carey, NC: SAS Institute, Inc.
- [25] Dauphinee, T. L., Schau, C., & Stevens, J. J. (1997). *Survey of Attitudes Toward Statistics: Factor structure and factorial invariance for females and males*. *Structural Equation Modeling, 4*(2), 129–141.
- [26] Hilton, S. C., Schau, C., & Olsen, J. A. (2004). *Survey of attitudes toward statistics: Factor structure invariance by gender and by administration time*. *Structural Equation Modeling, 11*(1), 92-109.

- [27] Tempelaar, D. T., van der Loeff, S. S., & Gijssels, W. H. (2007). A structural equation model analyzing the relationship of students' attitudes toward statistics, prior reasoning abilities and course performance. *Statistics Education Research Journal*, 6(2), 78-102.[Online: http://www.stat.auckland.ac.nz/~iase/serj/SERJ6%282%29_Tempelaar.pdf]
- [28] Araki, L. T. & Schultz, K.S. (1995). Students attitudes toward statistics and their retention of statistical concepts. Paper presented at the annual meeting of the Western Psychological Association, Los Angeles.
- [29] Jordan, J., & Haines, B. (2003). Fostering Quantitative Literacy. *Peer Review*, 5(4), 16-19.
- [30] Schield, M. (2004). *Statistical Literacy and Liberal Education at Augsburg College*. *Peer Review*, 6(4), 16-18.
- [31] Ginsburg, L. y Schau, C. (1997). *Monitoring Attitudes and Beliefs in Statistics Education*. En Gal, I. y Garfield, J. (Eds.)(1997). *The Assessment Challenge in Statistics Education*. Amsterdam, IOS Press and International Statistical Institute.
- [32] Auzmendi, E. (1992). *Evaluación de las actitudes hacia la estadística en alumnos universitarios y factores que las determinan*. [Evaluation of attitudes towards statistics in college students and factors which determine them] Unpublished doctoral thesis: Universidad de Deusto, Bilbao.
- [33] Mondéjar, J., Vargas, M., & Bayot, A. (2008). Measuring attitude toward statistics: the influence of study processes. *Electronic Journal of Research in Educational Psychology*, 16 (3), 729-748.
- [34] Woehlke, P.L. (1991). *An examination of the factor structure of Wise's Attitude Toward Statistics scale*. Annual Meeting of the American Educational Research Association, Chicago, IL, USA. (ERIC Document Repro).
- [35] Gil, J. (1999). *Actitudes hacia la estadística. Incidencia de las variables sexo y formación previa* [Incidence of the variables sex and previous training]. *Revista Española de Pedagogía*, 57(214), 567-590.
- [36] Elmore, P.B. and Lewis, E.L. (1991). *Statistics and computer attitudes and achievement of students enrolled in applied statistics: Effect of a Computer laboratory*. Chicago: American Educational Research Association Annual Meeting.
- [37] Cruise, R. J., Cash, R. W, & Bolton, D. L. (1985, August). *Development and validation of an instrument to measure statistical anxiety*. Paper presented at the annual meeting of the Statistical Education Section Proceedings of the American Statistical Association.
- [38] Schau, C. (2003). *Students' Attitudes: The "Other" Important Outcome in Statistics Education*. Parts of this paper were presented at the Joint Statistics Meetings, San Francisco. [Online: <http://evaluationandstatistics.com/JSM2003.pdf>. Access date 10/25/2011].
- [39] Vanhoof, S., Kuppens, S., Sotos, A. E. C., Verschaffel, L., & Onghena, P. (2011). *Measuring statistics attitudes: Structure of the Survey of Attitudes Toward Statistics (SATS-36)*. *Statistics Education Research Journal*, 10(1), 35-51. www.stat.auckland.ac.nz/~iase/serj
- [40] Mullis, I. V. S., M. O. Martin, E. J. Gonzalez, K. M. Conner, S. J. Chrostowski, K. D. Gregory, R. A. Garden and T. A. Smith (2001), *Mathematics Benchmarking Report*. Retrieved October 1, 2006 from http://timss.bc.edu/timss1999b/pdf/TB99_Math_all.pdf.
- [41] Farooq, M. S. & Shah, S. Z. (2008). *Pakistan Economic and Social Review, Students' attitude towards mathematics*, Vol. 46(1), pp. 75-85.
- [42] Blanco, A. (2008). *Una revisión crítica de la investigación sobre las actitudes de los estudiantes universitarios hacia la Estadística*. [A critical review of research on the college students' attitudes towards statistics] *Revista Complutense de Educación* 19 (2), 311-330.
- [43] García-Santillán, A.; Venegas-Martínez, F.; Escalera-Chávez, M.; Córdova-Rangel, A. (2013). *Attitude towards statistics in engineering college: An empirical study in public university (UPA)*. *Journal of Statistical and Econometric Methods* Vol. 2 Issue 1, 3 March pp 43-60.
- [44] Berkowitz, D., Wolkowitz, B., Fitch, R. & Kopriva, R. (2000) *The use of tests as part of high-stakes decision-making for students: a resource guide for educators and policy makers*. Washington, DC: US Department for Education.
- [45] Crocker, L., & Algina, J. (1986) *Introduction to classical and modern test theory*. Orlando, FL: Harcourt Brace Jovanovich.

- [46] Ebel, R. L. and Frisbie, D. A. (1991). *Essentials of educational measurement (5th ed.)*. Englewood Cliffs, NJ: Prentice Hall.
- [47] Rudner, L. M. (2001) *Computing the expected proportions of misclassified examinees*. *Practical Assessment, Research & Evaluation*, v7 n14.
- [48] Meadows, M. & Billington, L. (2005). *A review of the literature on marking reliability*. London: National Assessment Agency.
- [49] Raykov, T. & Marcoulides, G. A. (2010, in press). *Psychometric Theory*. New York: Routledge.
- [50] Fan, X. & Yin, P. (2003) *Examinee characteristics and score reliability: An empirical investigation*. *Educational & Psychological Measurement*, v63 n3 p357-368.
- [51] Wiliam, D. (2000) *Reliability, validity, and all that jazz*. *Education*, v29 n3 p9-13.
- [52] Harper, A. E. (1967) *Ninety marking ten: a study of examinations*. *Indian Educational Review*, v2 n1 p26-41.
- [53] Rosenthal, R. and Rosnow, R. L. (1991). *Essentials of Behavioral Research: Methods and Data Analysis*. Second Edition. McGraw-Hill Publishing Company, pp. 46-65.
- [54] Drost, Ellen A. "Validity and Reliability in Social Science Research." *Education Research and Perspectives* 38, no. 1 (June 2011): 105–23.
- [55] Bollen, K. A. (1989). *Structural equations with latent variables*. New York: Wiley.
- [56] Nunnally, J. C. (1978). *Psychometric Theory*. McGraw-Hill Book Company, pp. 86-113, 190-255.
- [57] Cortina, J. M. (1993). *What is coefficient alpha? An examination of theory and applications*. *Journal of Applied Psychology*, 78, 98-104.
- [58] Onwuegbuzie, A.J. (2000). *Attitudes toward Statistics Assessments*. *Assessment & Evaluation In Higher Education*, 25, 321-339.
- [59] IBM Corp. Released (2011). *IBM SPSS Statistics for Windows, Version 20.0*. Armonk, NY: IBM Corp.